

NATIONAL EXAMS DECEMBER 2008

98-CIV-B1 ADVANCED STRUCTURAL ANALYSIS

3 HOURS DURATION

NOTES:

1. If doubt exists as to the interpretation of any question, the candidate is urged to submit with the answer paper a clear statement of any assumption made.
2. Each candidate may use an approved model of Sharp or Casio calculator; otherwise, this is a CLOSED BOOK Examination.
3. Answer BOTH questions #1, and #2. Answer ONLY TWO of questions #3, #4, or #5. Answer ONLY TWO of questions #6, #7, #8 OR #9. SIX questions constitute a complete paper.
4. The marks assigned to each question are shown in the left margin.

FRONT PAGE

QUESTION #1 MUST BE ANSWERED.

- (8) 1. a) Determine the statical indeterminacy, r , of the structures shown below.
- b) Indicate with arrows (↻ a rotation; → a translation) on each structure and list beside each structure the number of structural degrees of freedom, k , that are required to do an analysis by the slope-deflection method. In each case, use the minimum number of structural degrees of freedom; where they occur, take into account symmetry, anti-symmetry and joints that are known to have zero moments.

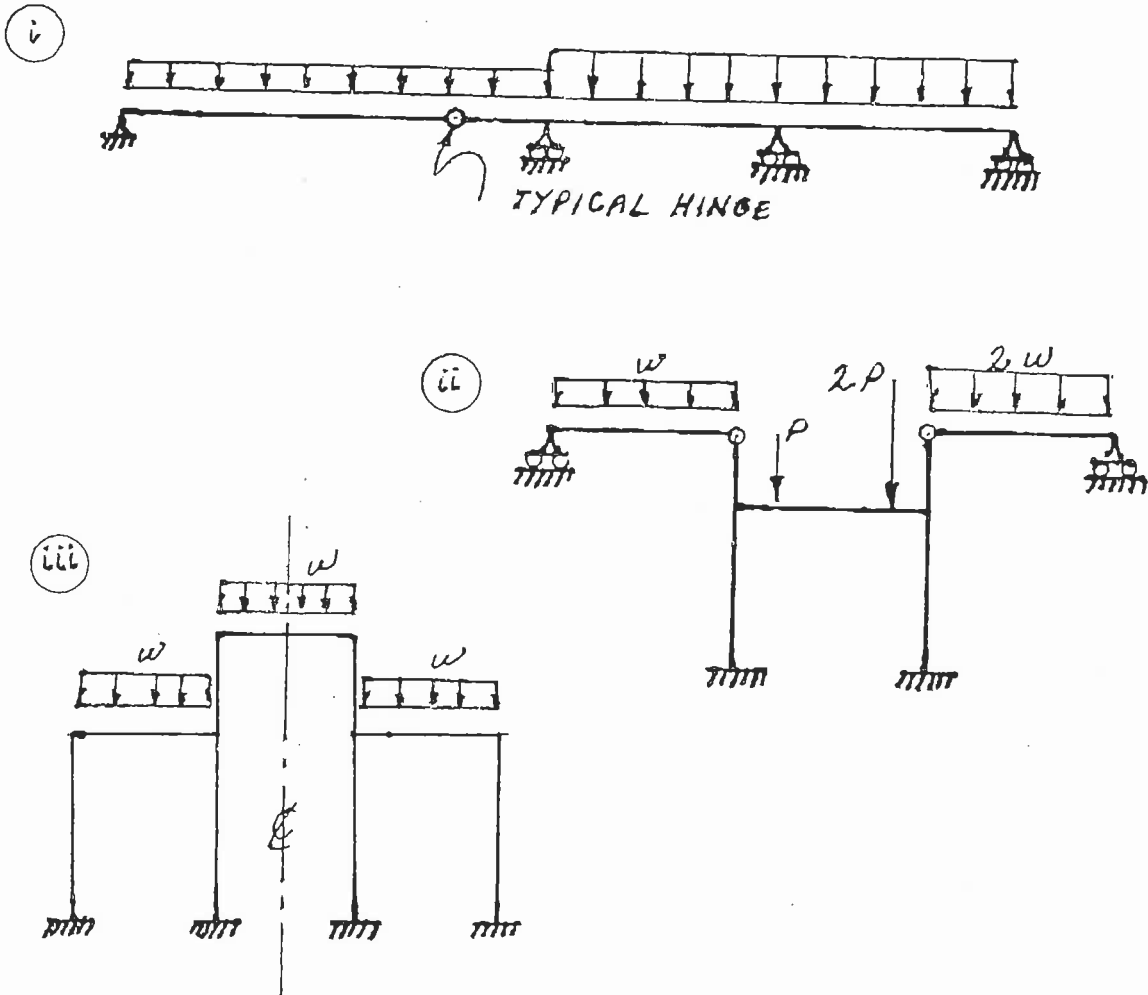

- (12) 2. Schematically show the shear force and bending moment diagrams for the following structures. All members have the same EI and are inextensible.

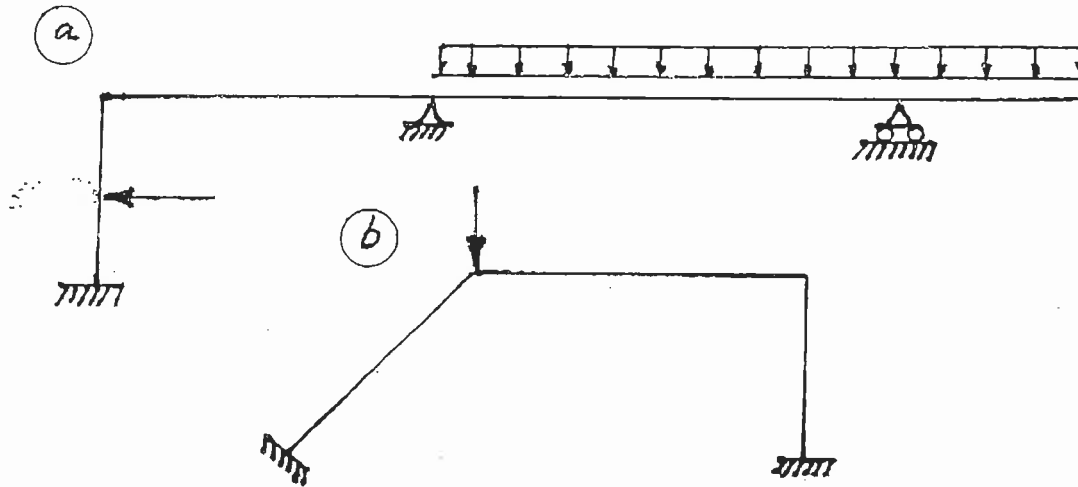

SELECT AND ANSWER TWO QUESTION ONLY FROM QUESTIONS 3, 4, OR 5.

- (18) 3. Use Castigliano's theorem (the least work theorem) to analyze the structure shown. Calculate the bending moment and shear at the left end of beam (A)-(B). The structure is symmetrical; take advantage of symmetry in the analysis. Note that the beams are hinged at the centre line of the structure. The two beams have $EI = 1.8 \times 10^5 \text{ kN.m}^2$. The two tension members have $AE = 5.0 \times 10^4 \text{ kN}$.

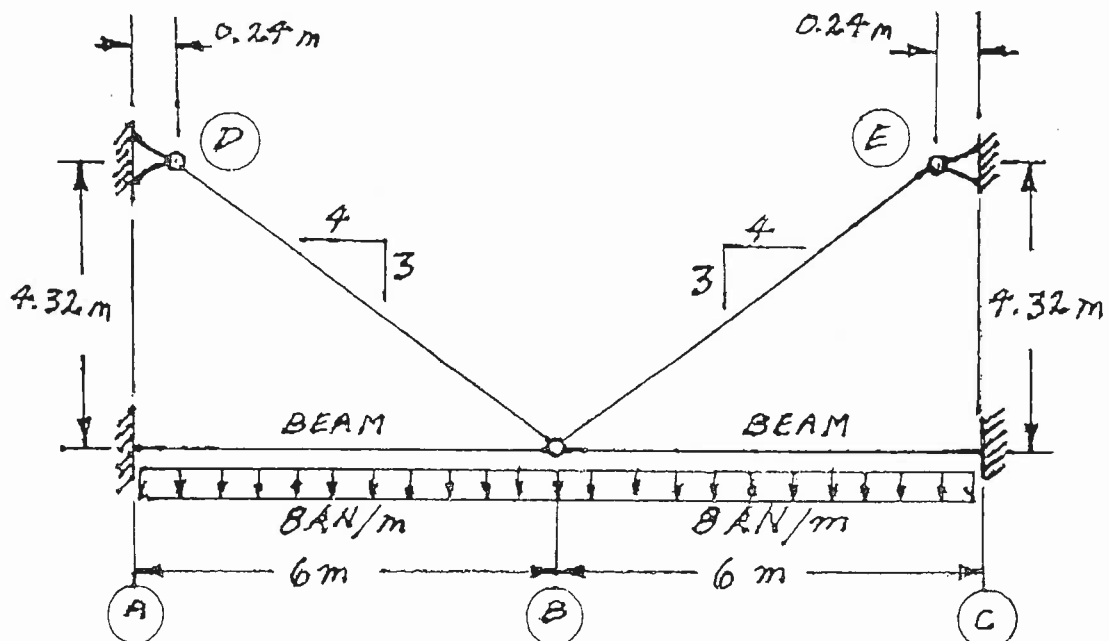

SELECT AND ANSWER TWO QUESTION ONLY FROM QUESTIONS 3, 4, OR 5.

- (18) 4. Use Castigliano's theorem to determine the vertical deflection at point (C) on the continuous beam structure shown. $EI = 1.12 \times 10^4 \text{ kN.m}^2$ for both beams.

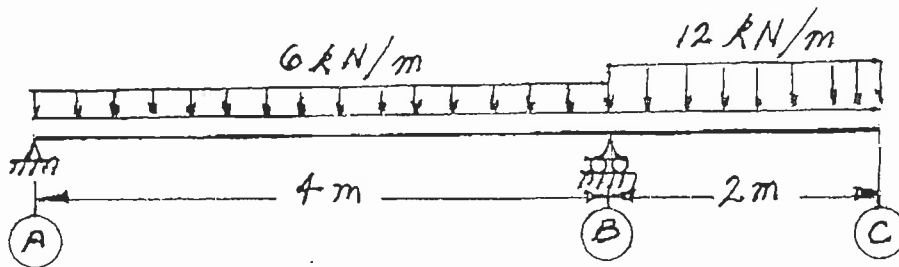

- (18) 5. From point (A) through point (D) sketch the influence line for bending moment immediately right of joint (B) in the frame structure shown below. Using the slope-deflection method or the moment-distribution method to analyze the structure, calculate the ordinate of the above influence line at the centre line of the structure. Members have the relative EI values shown and are inextensible. Take advantage of the structural symmetry in your analysis. State the units of the calculated ordinate.

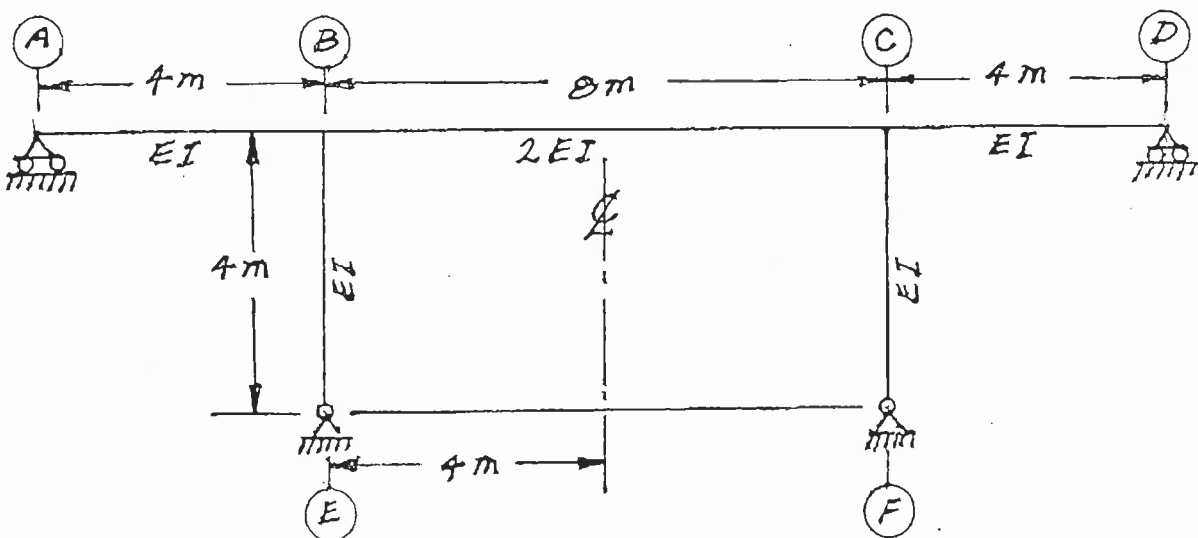

SELECT AND ANSWER TWO QUESTIONS ONLY FROM QUESTIONS 6, 7, 8 OR 9.

- (22) 6. Use the slope-deflection method or the moment-distribution method to analyze the frame structure shown. Draw shear and bending moment diagrams. On both diagrams for each member, indicate the magnitudes of maximum and minimum ordinates (Minimum ordinates are frequently negative values). In addition to the effects of the loads shown on the top two sloping members, stresses and strains are caused because both supports ① and ⑤ have moved 4 mm from their original positions; each moved outward, away from the centre line, as shown. All members are inextensible and have the relative EI values shown; $EI = 8.0 \times 10^4 \text{ kN.m}^2$.

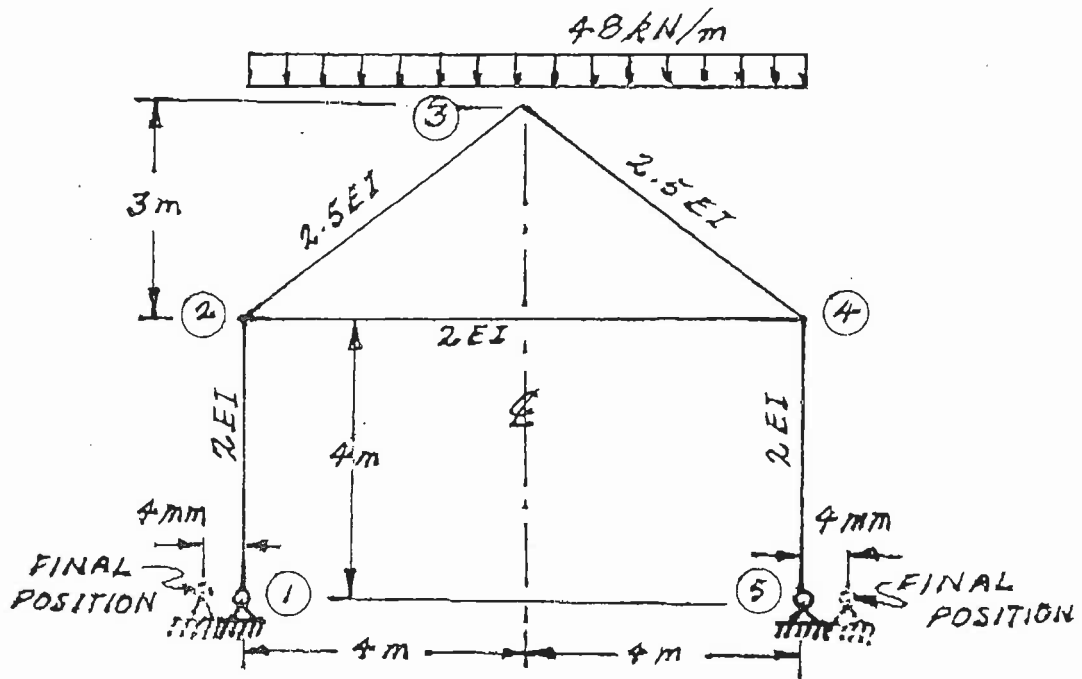

- (22) 7. Using a flexibility (force) method, determine the moments at the ends of the fixed-ended, non-prismatic beam shown below. The relative EI values are shown.

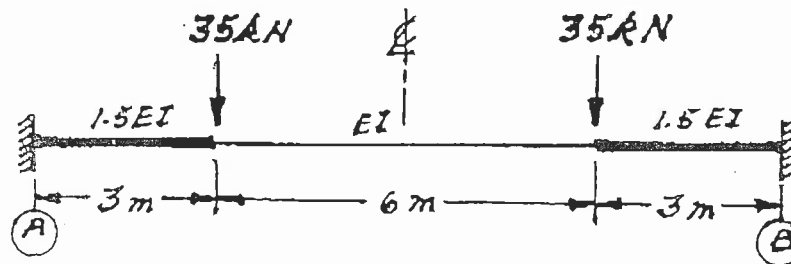

SELECT AND ANSWER TWO QUESTION ONLY FROM QUESTIONS 6, 7, 8 OR 9.

- (22) 8. Using the slope-deflection method, analyze the frame structure shown below. Plot shear force and bending moment diagrams. For each member on each diagram, indicate the magnitude of the maximum and minimum ordinates (Minimum ordinates are frequently negative values). All members are inextensible and have the same EI value.

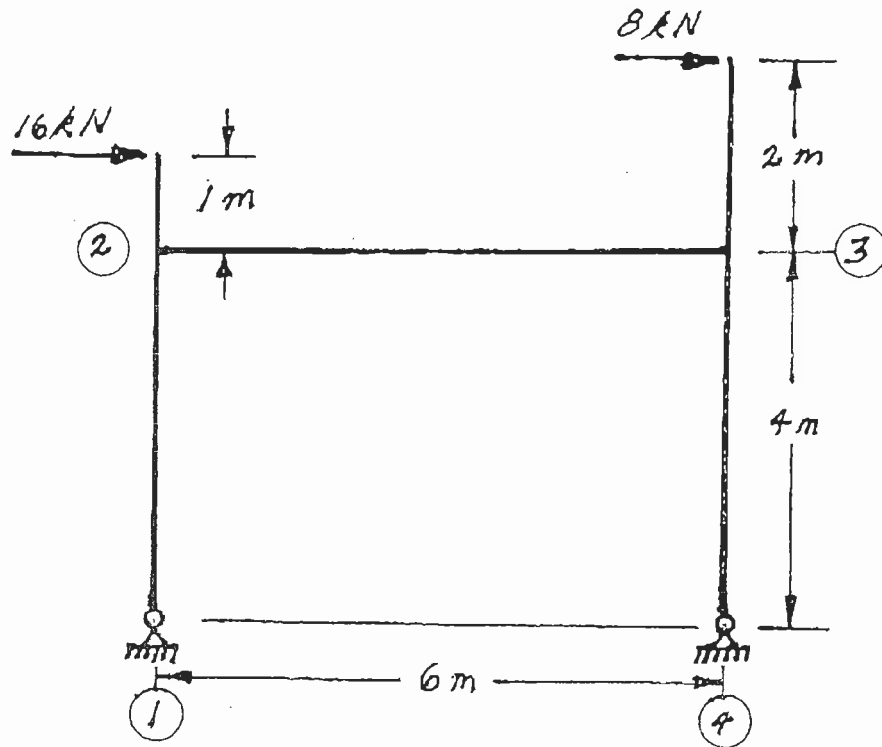

- (22) 9. a) For the frame shown, derive the equilibrium equation for the translation at joint (3) indicated on the diagram. Neglect the effects of axial strain. All members have the same EI value.
- b) Derive the equilibrium equations for moment equilibrium at joints (2) and (3).
- c) Present your results in matrix form by giving the terms of the stiffness matrix [K] and the load vector {P} in the following equation:

$$[K] \begin{Bmatrix} \delta \\ \theta_2 \\ \theta_3 \end{Bmatrix} = \{P\}$$

DO NOT SOLVE THE EQUATIONS.

The unknowns of the problem shall be:

δ = translation at joint (3) (positive in the direction indicated)

θ_2 = rotation of joint (2) }
 θ_3 = rotation of joint (3) } (positive counter clockwise)

