

PROFESSIONAL ENGINEERS ONTARIO

National Examinations – May 2010

07-Mec-A5, Electrical & Electronics Engineering

Mechanical Engineering

3 hours duration

Name [print]:

Signature:

Notes:

- [1] If doubt exists as to the interpretation of any question, the candidate is urged to submit, with the answer paper, a clear statement of any assumptions made.
- [2] Candidates may use one of two calculators, the Casio or Sharp approved models. This is a closed book examination.
- [3] Any five (5) questions constitute a complete paper. Only the first five questions as they appear in your answer book will be marked.
- [4] Each question is of equal value.
- [5] Clarity and organization of answers are important.
- [6] The candidate is required to sign this examination paper and submit it with the solution booklets.
- [7] $\pi = 3.14159$
 $1 \text{ hp} = 746 \text{ W}$
 $\mu_0 = 4\pi \times 10^{-7} \text{ H m}^{-1}$

QUESTION 1

Consider the circuit shown in Figure 1 which has been designed using ideal operational amplifiers (U_1 to U_3) with infinite bandwidth and infinite open loop gain. In the schematic, a , b and c are constants. You will note that U_3 is configured as a basic difference amplifier which has a transfer function given by:

$$E_0 = c (e_y - e_x)$$

where e_y and e_x are the potentials at points y and x respectively.

In the derivation of the transfer function for such circuits, one can assume:

- [i] Zero differential voltage between the input terminals of the operational amplifier,
- [ii] Zero current flows into either input terminal of the operational amplifier.

Applying the principle of superposition, derive an expression for the transfer function of the total circuit [E_0 as a function of E_1, E_2].

Hint: Let $E_2 = 0$, and solve for the potentials at points x and y for input E_1 .
 Let $E_1 = 0$, and again solve for the potentials at points x and y for input E_2 .
 Calculate the resultant output E_0 for both E_1 and E_2 inputs.

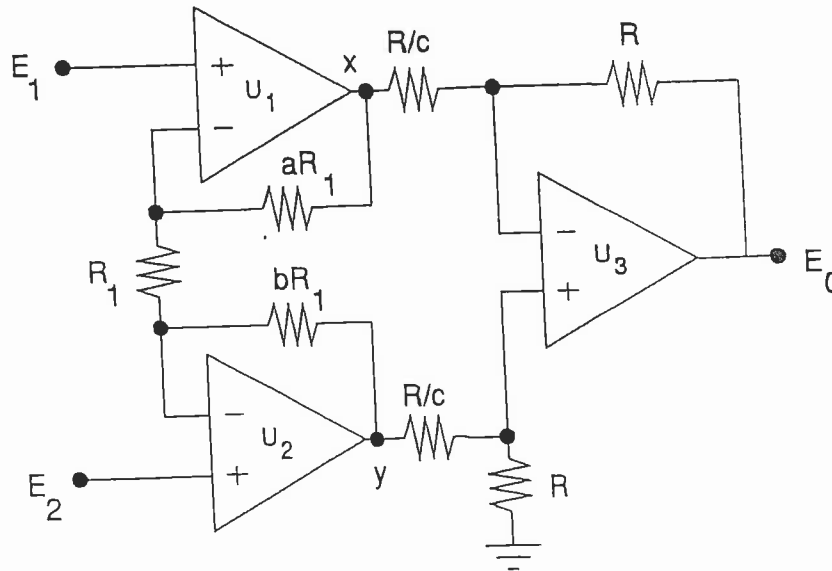

Figure 1 Circuit Schematic

QUESTION 2

Consider the transistor circuit shown in Figure 2. All transistors can be assumed to be identical with a dc current gain β .

Calculate the current transfer ratio for the circuit, I_2 / I_1 , as a function of β .

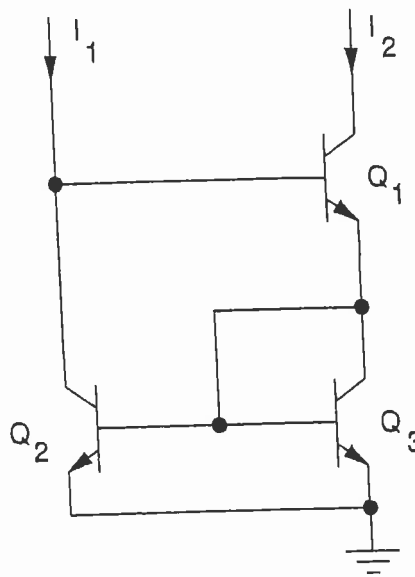

Figure 2 Transistor Circuit

QUESTION 3

A novel type of DC machine is designed using a disc type rotor of effective outer and inner diameters D and d respectively, as shown in Figure 3. A current I_2 is fed radially through the rotor via two ring shaped carbon brushes. The rotor lies in the horizontal plane and is situated in a vertical magnetic field of uniform density, B Tesla. The rotor spins at an angular speed ω rad/s.

- [a] Find the magnitude of the emf e generated between the brushes.
- [b] Determine the torque that the rotor will be subjected to and find the output horsepower of the machine.

HINT: As a starting point, consider an elemental annulus of radius r and radial length dr .

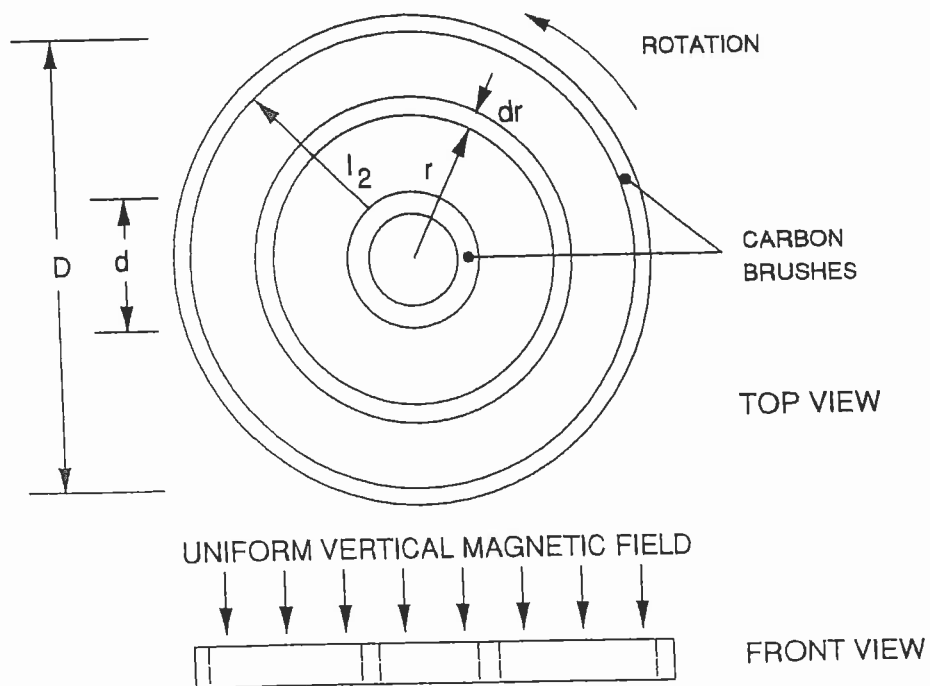

Figure 3 dc Machine

QUESTION 4

Consider the magnetic circuit of a transformer shown in Figure 4. Infinite relative permeability can be assumed for the iron core.

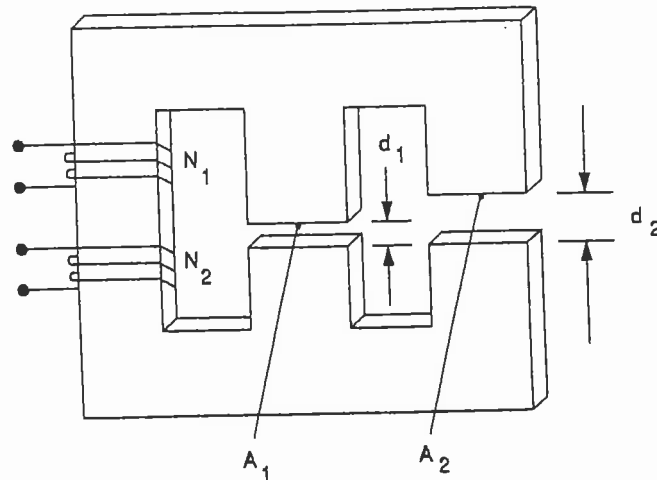

Figure 4 Transformer

The following specifications apply.

L_1	$3.77 \times 10^{-2} \text{ m}$	A_1	0.02 m^2
L_2	$7.54 \times 10^{-2} \text{ m}$	A_2	0.02 m^2
N_1 [primary]	200 turns	N_2 [secondary]	20 turns

When a dc voltage equal to 10 mV is applied to the primary, the measured primary current is 100 mA. When a dc voltage of 0.1 mV is applied to the secondary winding, the measured secondary current is 100 mA.

Assume that leakage inductances and eddy current and hysteresis losses are negligible; consider an operating frequency of 1000 Hz.

- [a] Draw the equivalent circuit of the transformer referred to the primary and calculate component values.
- [b] A transducer with an impedance of 0.078Ω is connected across the secondary of the transformer; an amplifier is connected to the primary. Calculate the output impedance of the amplifier to give maximum power transfer to the load.

QUESTION 5

This question consists of two parts which are not necessarily related.

Part I

A combinational logic circuit is shown in Figure 5.

- [a] Write a general Boolean algebra expression for the output F as a function of the inputs A, B.
- [b] Using DeMorgan's theorems and other Boolean identities, simplify the expression obtained in [a]. Is there a single gate which can replace the network shown?
- [c] Generate a truth table giving the logic levels at points C, D, E and F for inputs A,B.

Part II

Design a 2-input exclusive or (EOR) gate using only 2-input NOR gates.

- [d] Develop the truth table for the gate.
- [e] Write a general Boolean algebra expression for the output as a function of the inputs.
- [f] Using DeMorgan's theorems and other Boolean identities, modify the expression obtained in [e] to provide a solution which can be implemented with NOR gates.
- [g] Draw the circuit diagram for the final gate array.

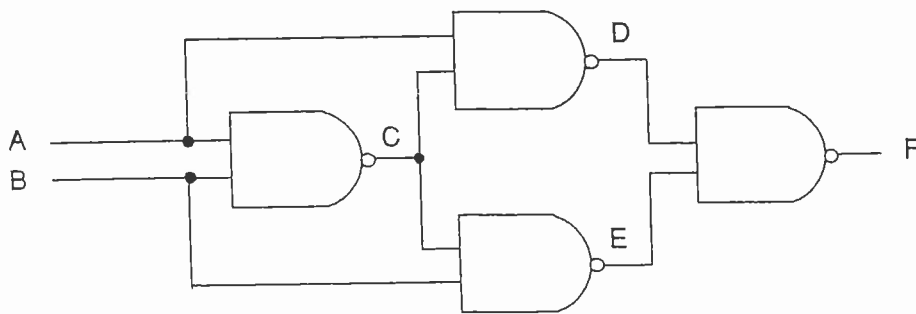

Figure 5 Combinational Logic Circuit

QUESTION 6

Consider the RC circuit shown in Figure 6[a]. The switch S_1 is closed at time $t=0$ connecting the dc supply V_1 to the network.

- [a] Derive an expression for the transfer function of the circuit, V_o/V_1 , in the time domain.
- [b] Sketch the transfer function for a time interval of 5 time constants.

The RC circuit is reconfigured as shown in Figure 6[b]. An ac voltage source of variable frequency v_i is connected to the input.

- [c] Derive an expression for the transfer function of the circuit, v_o/v_i , in the frequency domain.
- [d] Sketch the magnitude of the transfer function for a frequency range of 4 decades centered at the corner frequency of the circuit.

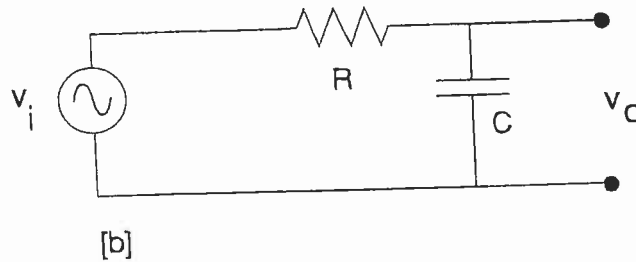
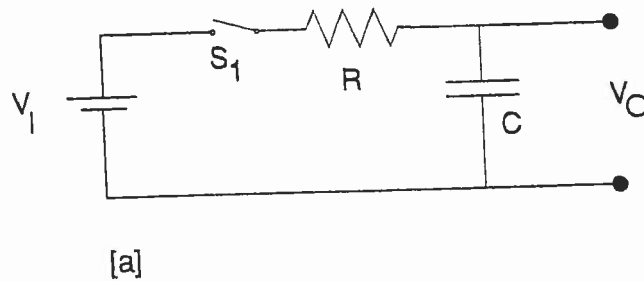

Figure 6 RC Circuit: [a] dc test; [b] ac test

QUESTION 7

The results of no-load and blocked-rotor tests conducted on a three-phase wye-connected induction motor are as follows:

No-load test:

line-to-line voltage: 400V
input power: 1770W
input current: 18.5A
friction and windage loss: 600W

Blocked-rotor test:

line-to-line voltage: 45V
input power: 2700W
input current: 63A

- [a] Sketch the equivalent circuit of the induction motor and identify all parameters.
- [b] Determine the parameters of the equivalent circuit of the induction motor.

QUESTION 8

An industrial load is represented in Figure 8 by $R = 6\Omega$ and $X_L = 8\Omega$. The load voltage is $250\angle 0^\circ$ V.

- Calculate the load current, power, reactive power and power factor.
- Calculate the generator voltage V_G required at the input end of the transmission line (represented by the series impedance $Z_T = (1 + j3)\Omega$) and the power lost in transmission P_T .
- If capacitor $X_C = 12.5\Omega$ is connected in parallel by closing switch S, calculate I_C , the new load current I, and the new power factor. Show V , I_L , I_C , and I on a phasor diagram.
- Calculate the new generator voltage and the new transmission power loss.
- What two advantages do you see for improving the power factor by adding a parallel capacitor?

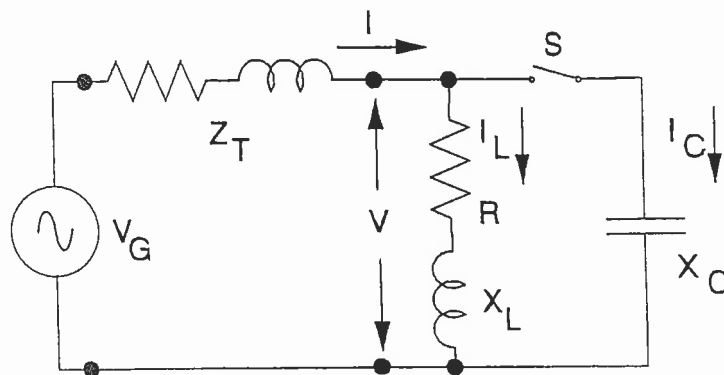

Figure 8 Industrial Load