

NATIONAL EXAMS MAY 2012

98-CIV-A1 ELEMENTARY

STRUCTURAL ANALYSIS

3 HOURS DURATION

NOTES:

1. If doubt exists as to the interpretation of any question, the candidate is urged to submit with the answer paper a clear statement of any assumption made.
2. Each candidate may use an approved model of Sharp or Casio calculator; otherwise, this is a CLOSED BOOK Examination.
3. Six questions constitute a complete paper. Answer ALL questions #1 through #5; answer ONLY ONE of #6, #7 or #8. Six questions constitute a complete paper.
4. The marks assigned to each question are shown in the left margin.

FRONT PAGE

- (6) 1. For each of the structures shown state whether it is unstable, statically determinate, or statically indeterminate. If the structure is statically indeterminate, state the degree of indeterminacy. Structures a) through d) have beam-type members.

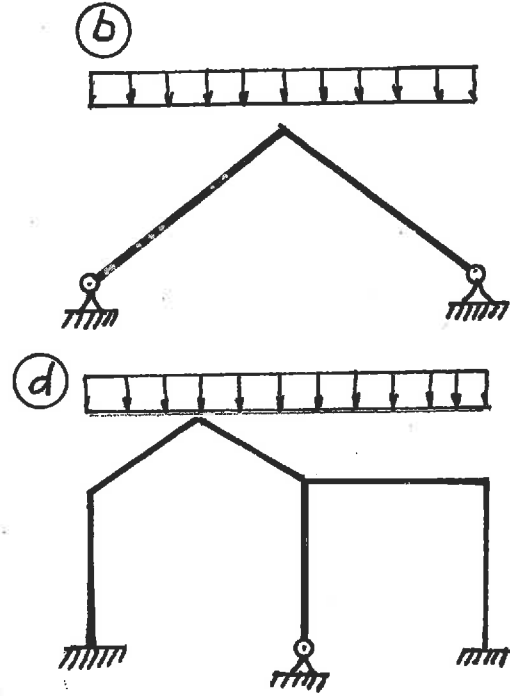
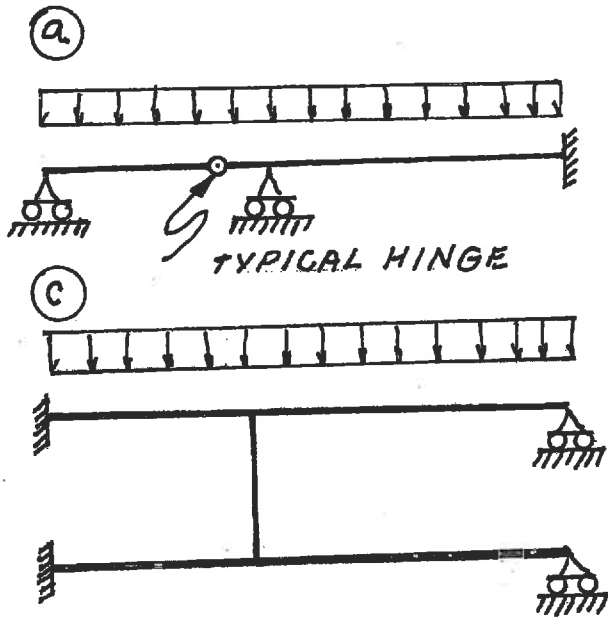

Structures e) and f) have truss-type members. Diagonals are not connected where they cross.

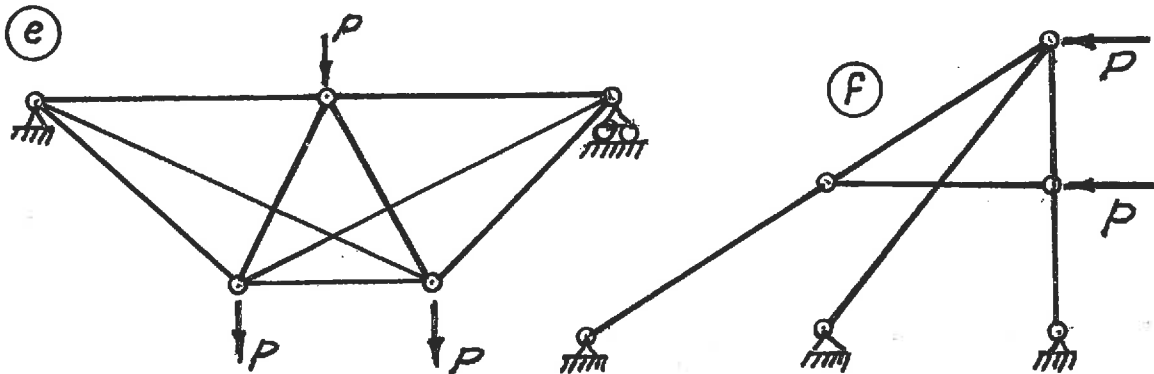

- (18) 2. For each structure shown, compute the reactions and draw shear and bending moment diagrams. Indicate which are positive and which are negative segments of each bending moment diagram. For each shear and bending moment diagram, calculate and indicate the magnitudes of the maximum positive and negative ordinates.

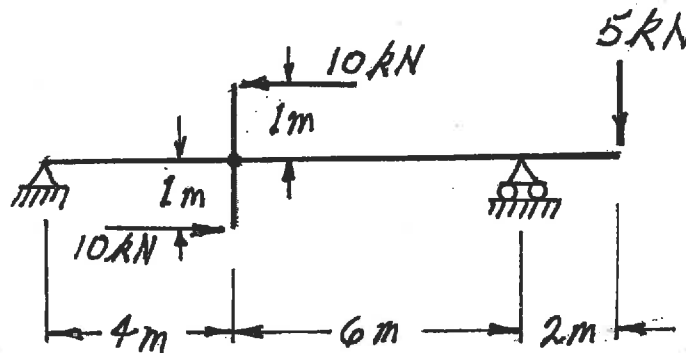
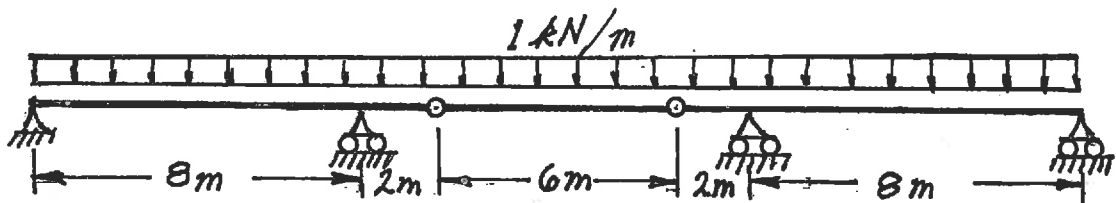
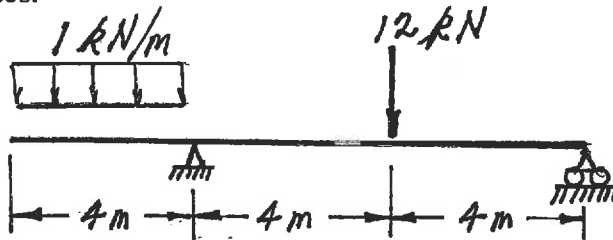

- (17) 3. Calculate the vertical deflection of the beam under the  $24 \text{ kN}$  point load. The beam has an  $EI = 27000 \text{ kN.m}^2$ .

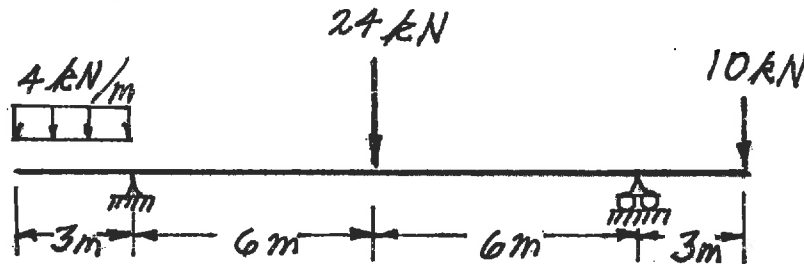

(21) 4. For the trusses shown below, calculate the forces in the members that are listed. For each force, indicate whether it is tension or compression.

a) Calculate the forces in:  $L_3 - L_4$ ,  $U_3 - L_4$  and  $U_3 - U_4$

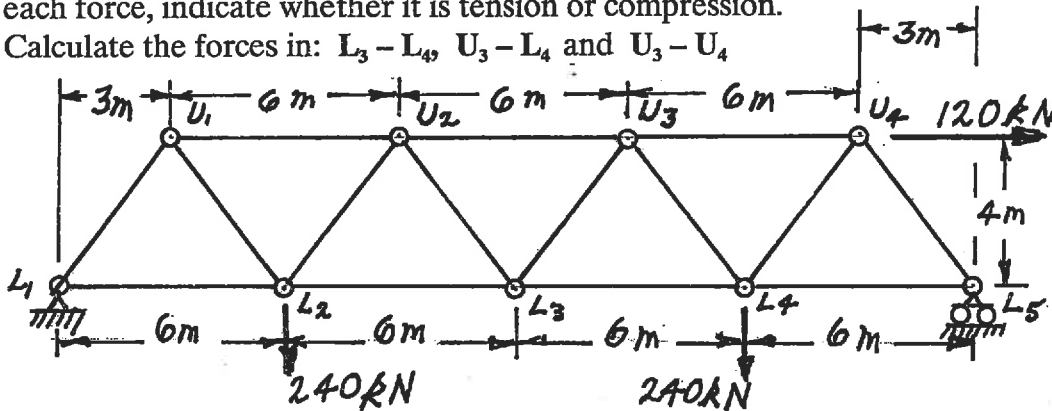

b) Calculate the forces in:

- $U_2 - U_3$
- $L_1 - M$
- $L_1 - U_2$  and
- $U_2 - M$

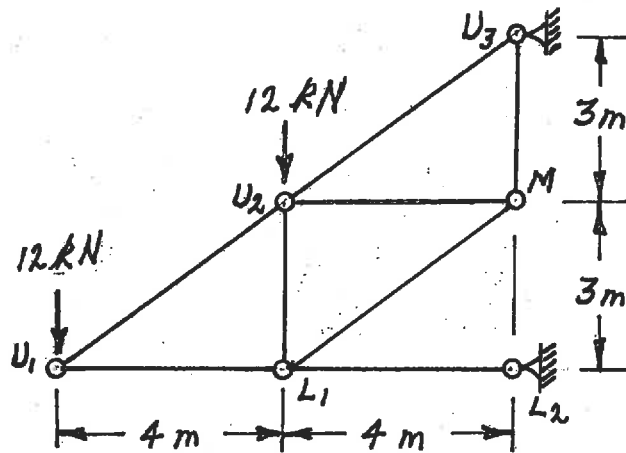

(18) 5. For the beams shown below, using the moment-distribution method or the slope-deflection method, calculate and plot the shear force and bending moment diagrams. On both diagrams, for each member, indicate the maximum and minimum ordinates (Minimum ordinates are frequently negative values). The members have the relative EI values shown and are inextensible.

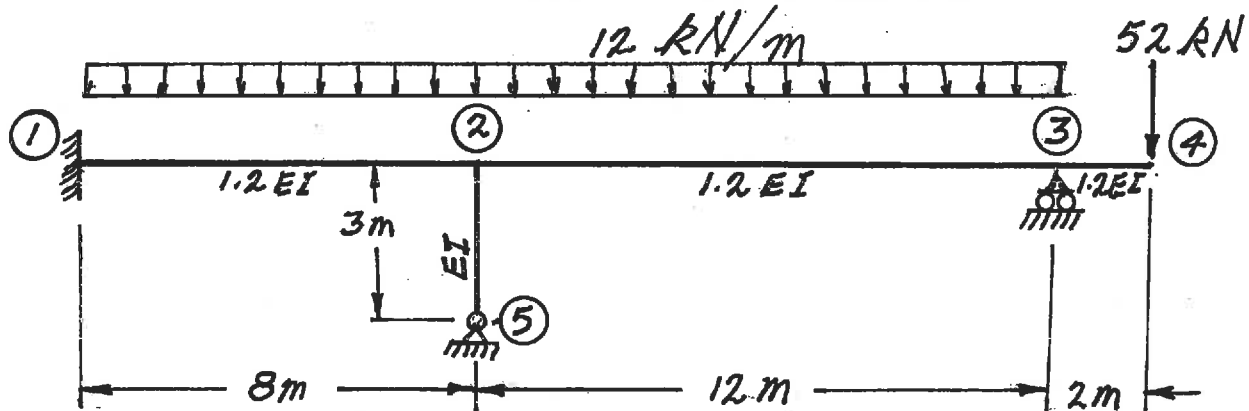

Select and answer ONE QUESTION ONLY from Questions #6, #7 or #8.

- (20) 6. a) Loads move along beams at the top chord level of the truss shown. Draw influence lines for forces in the members listed beside the truss. For each influence line, calculate and indicate the value of the influence coefficient that has the maximum absolute value.

$U_2 - L_2$   
 $U_3 - L_2$   
 $U_3 - L_3$

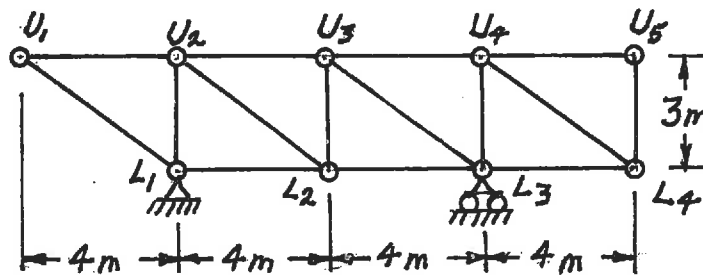

- b) A vehicle, which is idealized as a uniformly distributed load over a length of 4 m, moves across the frame structure shown below. Calculate and show the influence line for bending moment immediately right of joint (B). Also calculate the largest negative bending moment immediately right of (B) caused while the idealized vehicle crosses the structure.

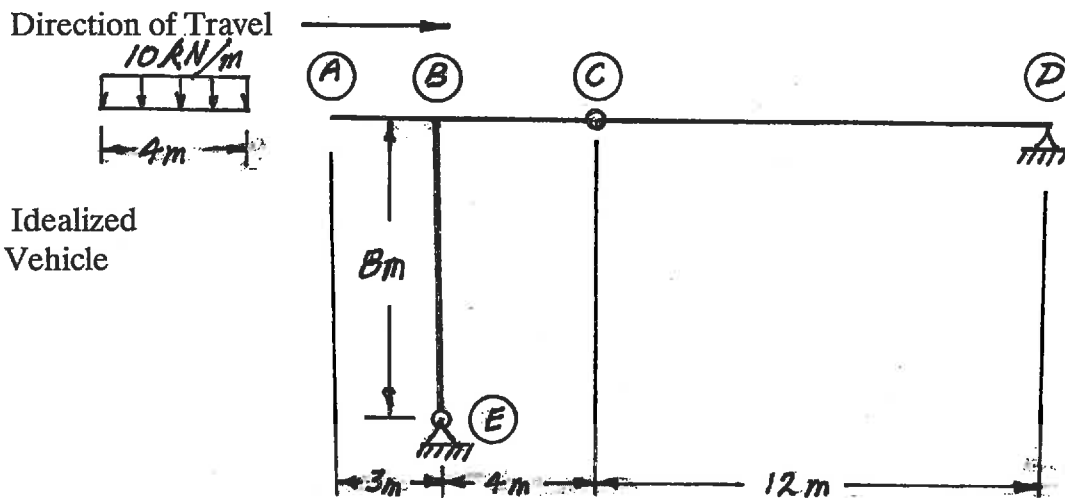

Select and answer TWO QUESTIONS ONLY from Questions #6, #7 or #8.

- (20) 7. Use the principle of virtual work to calculate the vertical deflection at the apex, point **C**, on the structure shown below. All members have the same EA which is  $3.15 \times 10^4$  kN.

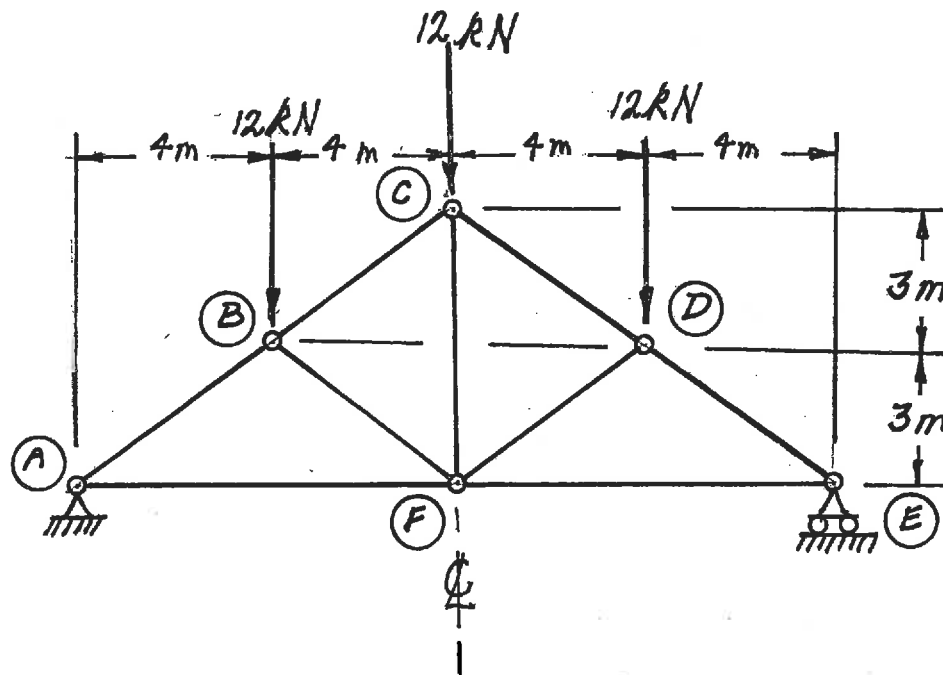

Select and answer **TWO QUESTIONS ONLY** from Questions #6, #7 or #8.

- (20) 8. For the structure shown below, compute the reactions and draw shear and bending moment diagrams. On both diagrams, for each member, calculate and indicate the maximum and minimum ordinates (Minimum ordinates are frequently negative values).

