

NATIONAL EXAMS DECEMBER 2014

98-CIV-A1 ELEMENTARY

STRUCTURAL ANALYSIS

3 HOURS DURATION

NOTES:

1. If doubt exists as to the interpretation of any question, the candidate is urged to submit with the answer paper a clear statement of any assumption made.
2. Each candidate may use an approved model of Sharp or Casio calculator; otherwise, this is a CLOSED BOOK Examination.
3. Six questions constitute a complete paper. Answer ALL questions #1 through #5; answer ONLY ONE of #6, #7 or #8.
4. The marks assigned to each question are shown in the left margin.

FRONT PAGE

- (6) 1. For each of the structures shown state whether it is unstable, statically determinate, or statically indeterminate. If the structure is statically indeterminate, state the degree of indeterminacy. Structures a) through d) have beam-type members.

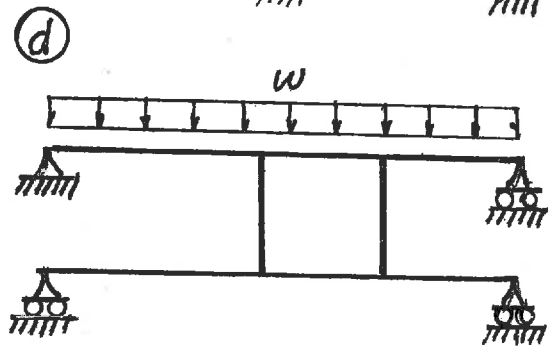
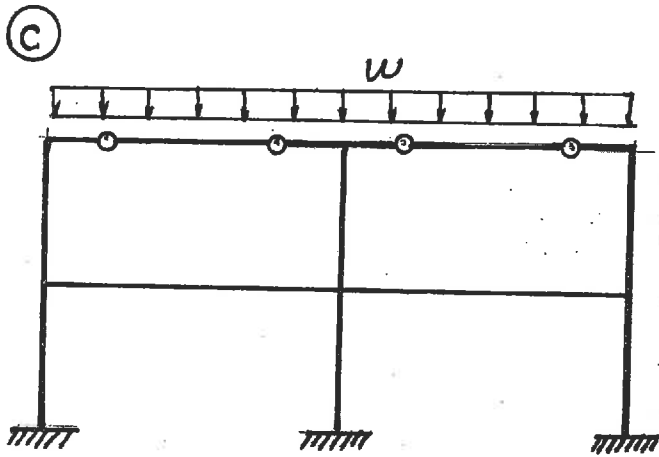
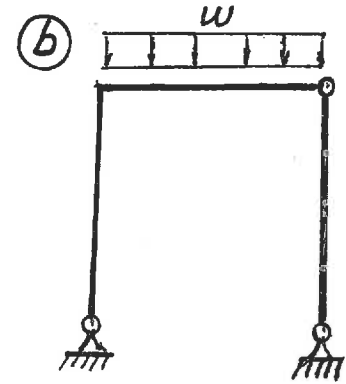
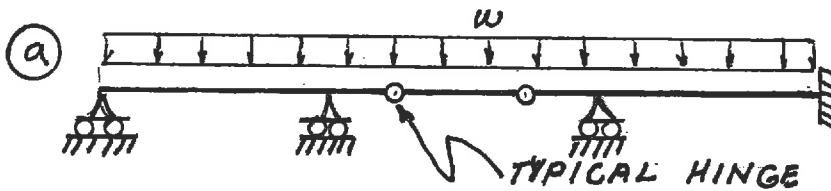

Structures e) through f) have truss-type members.
Diagonals are not connected where they cross.

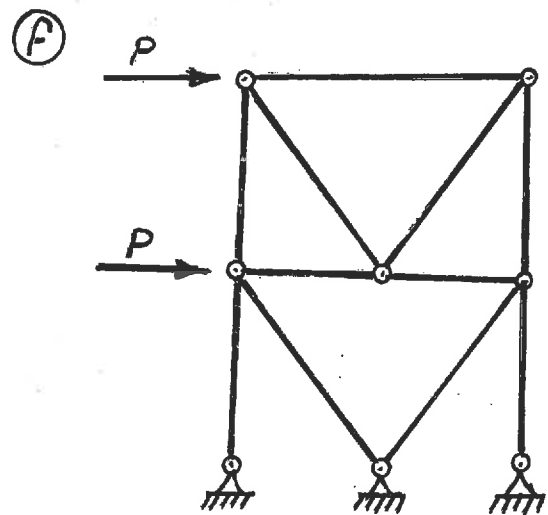
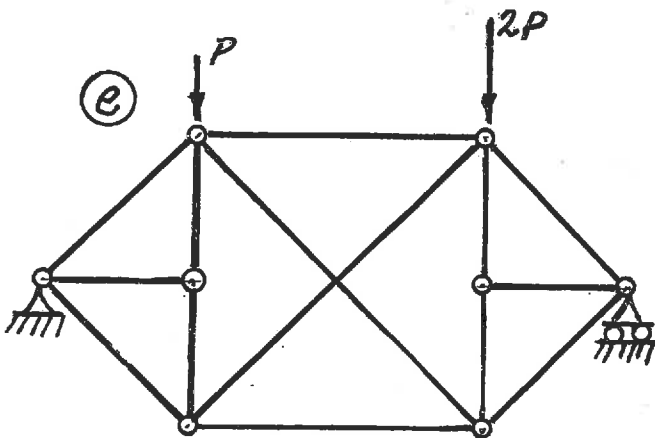

- (18) 2. For each structure shown, compute the reactions and draw shear and bending moment diagrams. Indicate which are positive and which are negative segments of each bending moment diagram. For each shear and bending moment diagram, calculate and indicate the magnitudes of the maximum positive and negative ordinates.

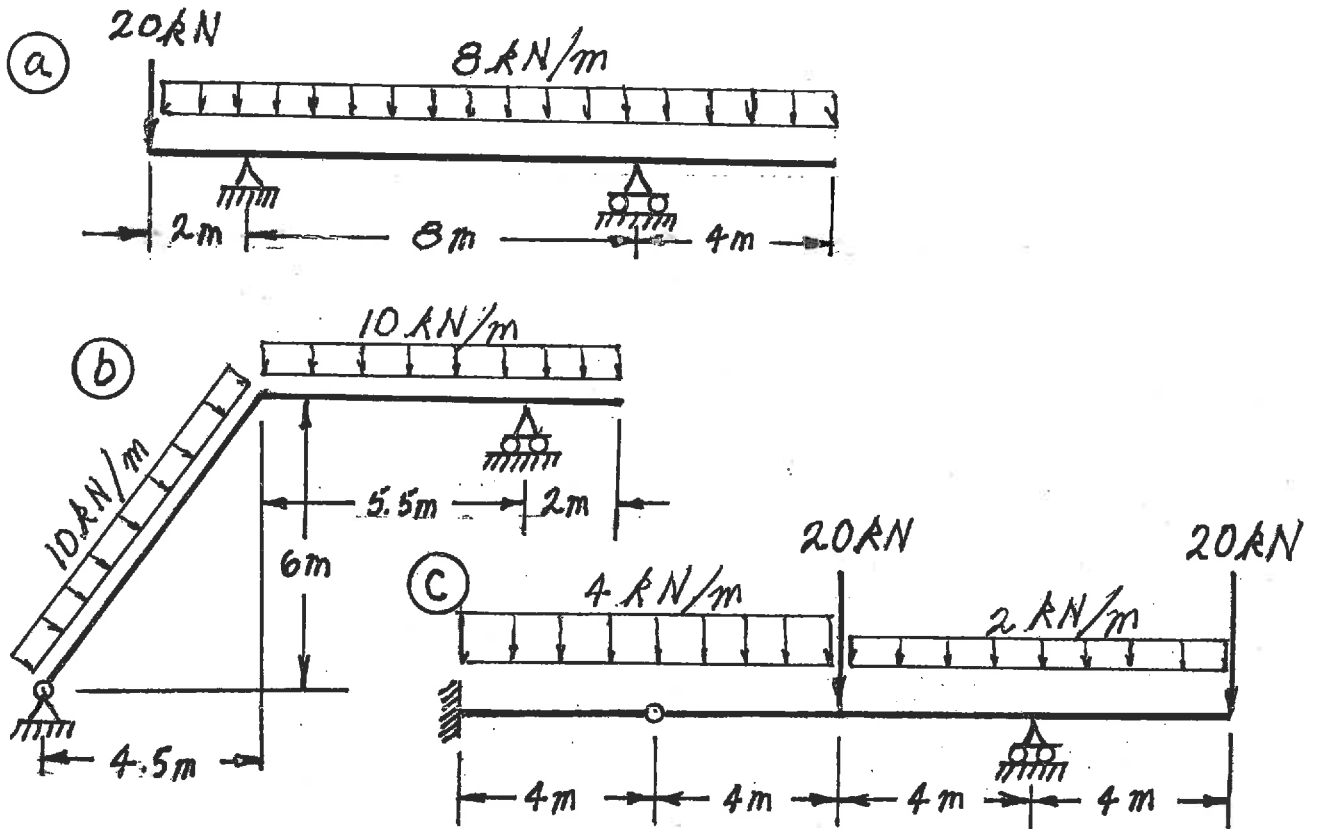

- (18) 3. Calculate the vertical deflection at point (B) on the structure shown below. $EI = 7.5 \times 10^4 \text{ kN.m}^2$. Relative EI values are shown on the diagram below.

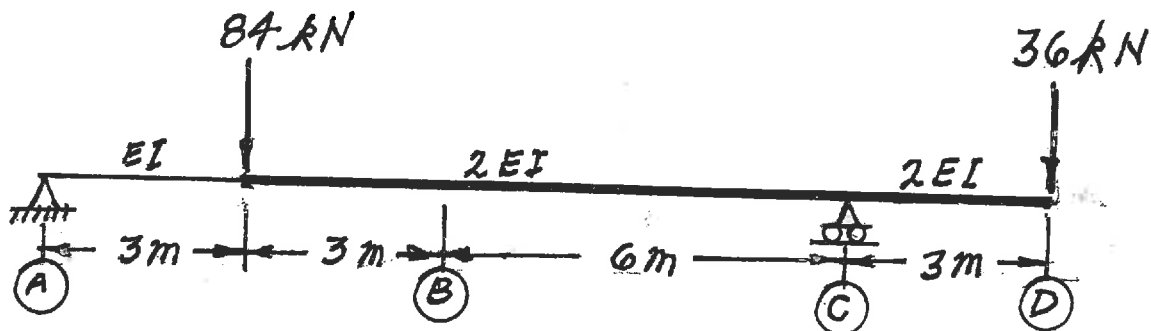

(18) 4. For the trusses shown below, calculate the forces in the members that are listed. For each force, indicate whether it is tension or compression.

a) Calculate the forces in:

- $U_1 - L_1$
- $L_1 - L_2$ and
- $U_2 - L_2$

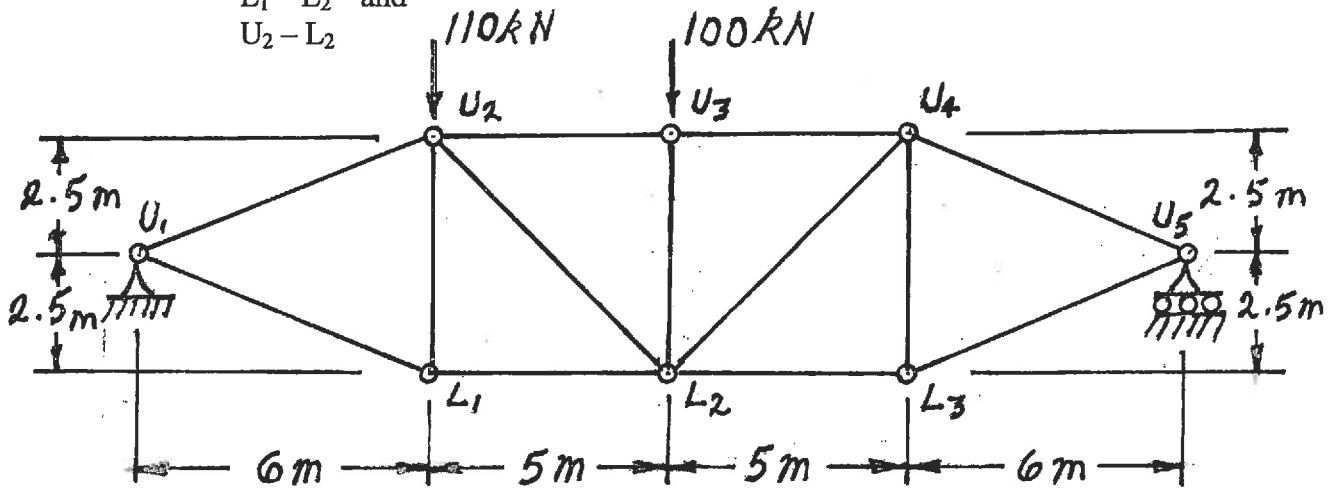

b) Calculate the forces in:

- $U_1 - U_2$
- $U_1 - M_1$ and
- $L_1 - M_1$

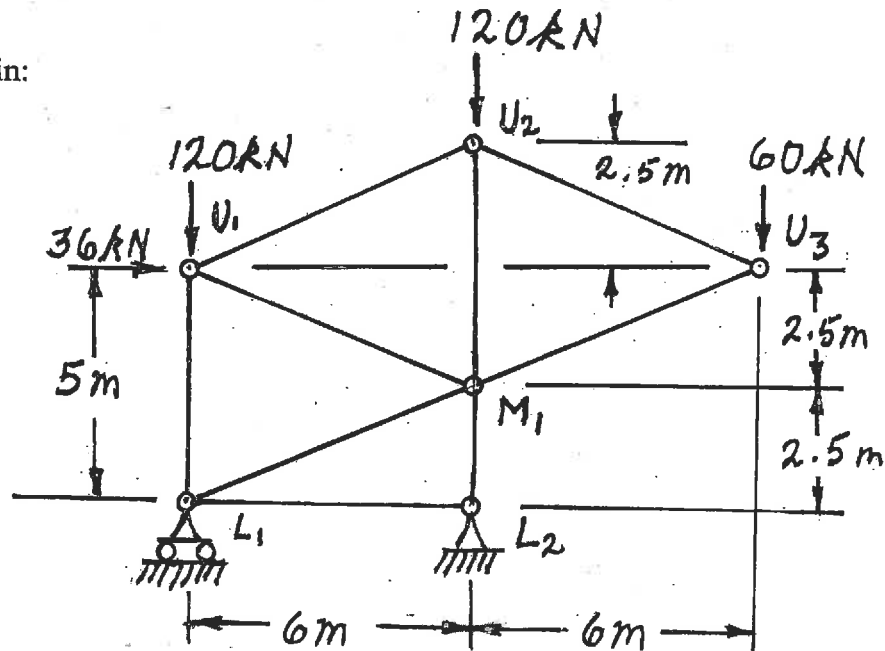

(20) 5. a) For the determinate, three-span structure shown, draw the influence lines for:

- i) bending moment at point (B)
- ii) bending moment at mid span of span (B)–(C)
- iii) reaction at support (A)

For each influence line, calculate and indicate the value of the influence coefficient that has the maximum absolute value.

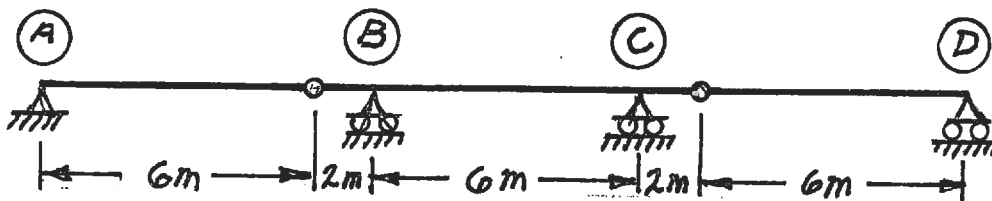

- b) A vehicle, which is idealized as the three point loads spaced as shown below, moves across the two-span, determinate beam structure shown. Calculate and show the influence line for shear immediately right of support (B). Show the maximum ordinates in each span on a sketch of the influence line and calculate the maximum shear immediately right of support (B) caused by the vehicle as it crosses the structure.

Idealized Vehicle

Direction of Travel

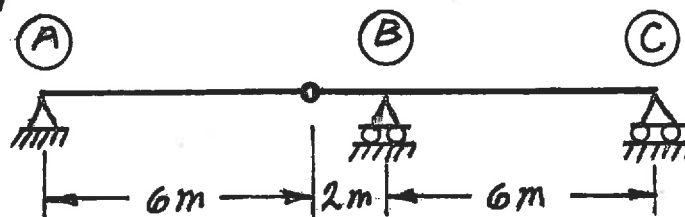
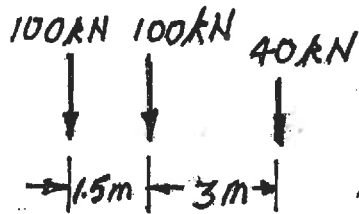

.....
 Select and answer ONE QUESTION ONLY from Questions #6, #7 or #8.

- (20) 6. For the frame shown below, using the moment-distribution method or the slope-deflection method, calculate and plot the shear force and bending moment diagrams. On both diagrams, for each member, label the maximum and minimum ordinates (Minimum ordinates are frequently negative values). Members have the relative EI values shown on the diagram and are inextensible.

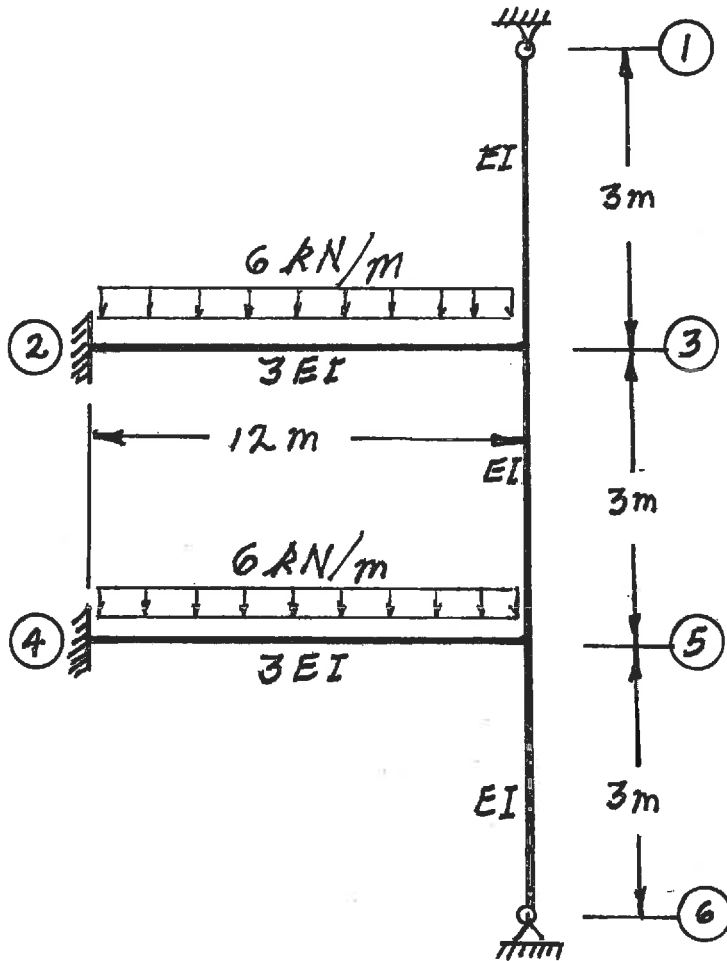

Select and answer ONE QUESTION ONLY from Questions #6, #7 or #8.

- (20) 7. For the structure shown below, compute the reactions and draw shear and bending moment diagrams. On both diagrams, for each member, calculate and label the maximum and minimum ordinates (Minimum ordinates are frequently negative values).

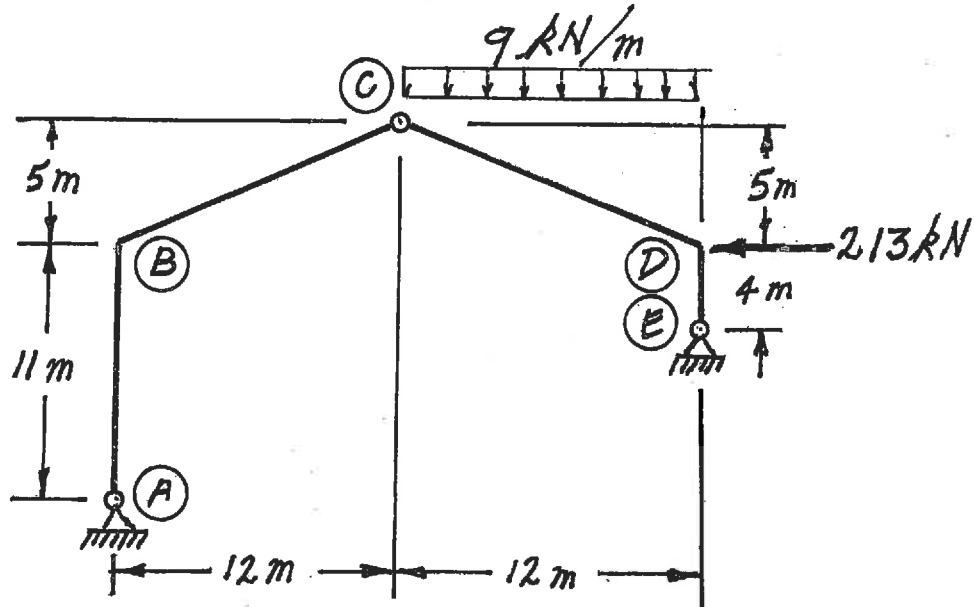

- (20) 8. Using the principle of virtual work, calculate the horizontal deflection at point C of the structure shown below. The tie rod has an $AE = 4.5 \times 10^4$ kN. Both beams are inextensible and have $EI = 2.4 \times 10^5$ kN.m².

