

National Exams May 2014  
07-Mec-B1, Advanced Machine Design

Notes

- Time: 3 hours.
- This is an open book exam.
- Answer all questions of Part I (i.e. Questions 1, 2), and only THREE questions from Part II of the examination.
- Make sure your answers are neat and clear.
- State all assumptions clearly. If doubt arises as to the interpretation of any question, write down a clear statement of any assumptions made.
- All answers must be clearly annotated with a summary of the approach, method, and results written in clear and correct English.
- Document your sources of information whenever you use a tabulated value or an equation.
- Any non-communicating calculator is permitted.
- Assume any missing data and make sure to properly state in your answer.
- The examination marks 100 in total.
- Failure to follow the above directions will result in grade penalties.

PART I

**Problem 1.** Briefly answer the following questions:

- Why yielding occurs at a higher stress in plane strain condition than the tensile yield strength? (3 marks)
- List a couple cases when solid film lubricants are used rather than liquid lubricants, and explain the reasons. (3 marks)
- What is fretting corrosion? (2 marks)
- How does the mean stress affect the fatigue behavior of material? (2 marks)

**Problem 2.** A common shaft with two gears on it is shown in the following figure. Two constant radial forces of 250 lb and 750 lb are applied at the left and right gear, respectively. The shaft is subjected to a time-varying torque from the minimum of  $-200 \text{ lb}\cdot\text{in}$  to the maximum of  $400 \text{ lb}\cdot\text{in}$ . Find the diameter of shaft required to obtain a safety factor of 2 in fatigue loading if the shaft is steel of ultimate strength  $S_{ut} = 108 \text{ ksi}$  and yield strength  $S_y = 62 \text{ ksi}$ . What would be the maximum deflection in bending of the shaft? (30 marks)

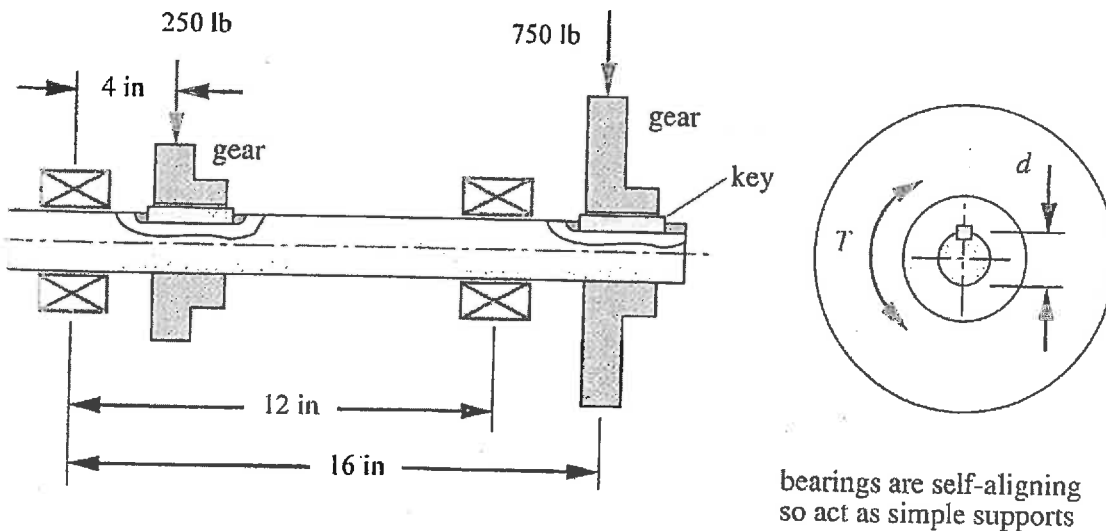

## Part II

**Problem 3.** A stepped, round shaft is loaded as shown in the following figure. Find out (1) the maximum deflection and its location along the shaft, and (2) the fundamental critical rotating speed for the shaft. (20 marks)

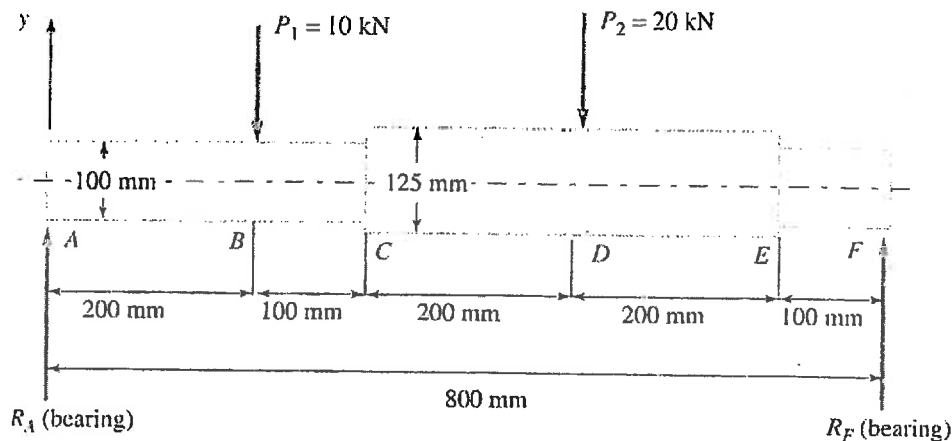

**Problem 4.** A journal and bearing are to be designed for a shaft that turns at 250 rpm. Suppose ISO VG100 (SAE Engine 30) is to be used as lubricant and the bearing length is to be equal to 1.2 times the diameter. If the no-load power loss is not to exceed  $2.5 \times 10^{-4}$  horsepower and the diametral clearance is 0.0045 times the diameter, estimate the maximum diameter that can be used for the journal, and the allowable temperature limit. (20 marks)

**Problem 5.** Design a single-surface disk clutch to transmit 100 N.m of torque at 750 rpm using a molded lining with a maximum pressure of 1.2 MPa and friction coefficient of 0.25. Assume uniform wear. Find the outside and inside diameters required using an inside to outside diametral ratio of 0.577. What is the power transmitted? (20 marks)

**Problem 6.** For a double short-shoe external drum brake with a drum width of 60 mm as shown in the following figure, find the torque capacity and required actuating force  $F_a$  for  $a = 90 \text{ mm}$ ,  $b = 80 \text{ mm}$ ,  $e = 30 \text{ mm}$ ,  $r = 40 \text{ mm}$ , and  $\theta = 30^\circ$ . What value of  $c$  will make it self-locking? Assume the maximum allowable lining pressure is 1.3 MPa and the friction coefficient for the brake lining material is  $\mu = 0.3$ . (20 marks)

