

National Exams May 2016
07-Elec-B7, Power Systems Engineering
Open Book examination

3 hours duration

NOTES

1. If doubt exists as to the interpretation of any question, the candidate is urged to submit, with the answer paper, a clear statement of any assumptions made.
2. Any non-communicating calculator is permitted. This is an Open Book examination. Note to the candidates: you must indicate the type of calculator being used, i.e. write the name and model designation of the calculator on the first inside left hand sheet of the exam work book.
3. Any five questions constitute a complete paper. Only the first five questions as they appear in your answer book will be marked.
4. All questions are of equal value.

Problem 1

Consider the network shown in Figure (1,) with a round rotor synchronous machine feeding a load through two parallel lines. Assume for the first line linking buses 1 and 2 that the parameters A and B in per unit are given by:

$$A_1 = 0.996$$

$$B_1 = j0.02$$

In addition, the per unit series impedance and shunt admittance parameters of the second line (represented by an equivalent pi) are $Z_2 = j0.05$ and $Y_2 / 2 = j0.02$

- Convert the A_1 and B_1 parameters to equivalent pi network Z_1 and Y_1 . [5 points]
- Reduce the two parallel lines to one equivalent line represented by Z_{eq} and $Y_{eq}/2$ [5 points]
- Suppose now that the magnitude of the voltage at bus 2 is 1.00 p.u. and that the active power load at bus 2 in per unit is 1.25 at 0.85 p.f. lagging. Determine the values of voltage, phase angle, active and reactive power at bus 1 (the synchronous machine terminals.) [5 points]
- Find the required synchronous machine excitation voltage and power (torque) angle assuming that the machine's synchronous reactance is $X_s = 0.03$ p.u. Note that all power formulae in the text are given with bus 1 being the reference with phase angle = 0.00 [5 points]

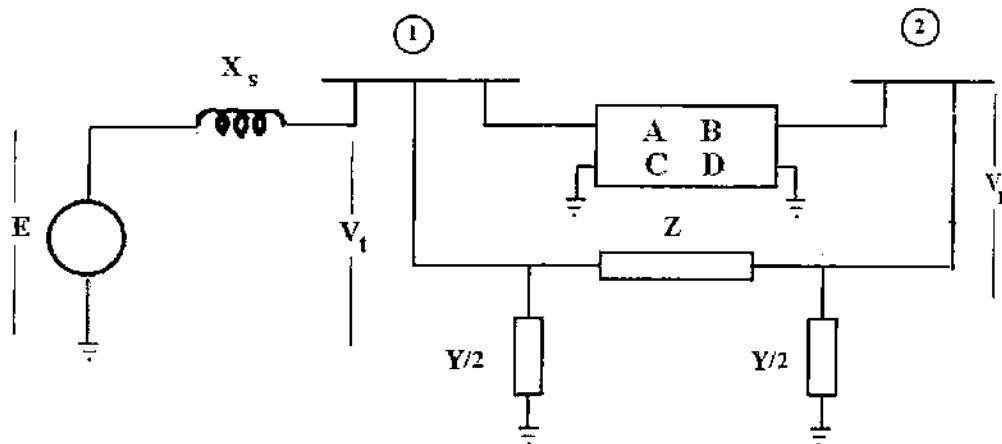

Figure (1) Electric network for Problem 1

Problem 2

- a- Explain why it is important to provide sufficient reactive power throughout an electric power system. List the major sources of reactive power in the system. [5 points]
- b- A salient pole synchronous machine is connected to an infinite bus whose voltage is kept constant at 1.00 pu. The direct and quadrature axis reactances of the machine are 0.6 and 0.3 pu respectively. The table given below relates to three operating conditions of the machine. (Q_2 is the reactive power at machine terminals) Complete the table neglecting armature reaction. [15 points]

	P	Q_2	E	δ
Condition A	2.0	?	?	45°
Condition B	?	?	1.25	40°
Condition C	?	0.0	1.15	?

Problem 3

- a- A 500 KVA, 2300/230 V single phase transformer delivers full rated KVA at 0.85 p.f. lagging to a load at rated secondary voltage. The primary voltage magnitude is 2400 V under these conditions and the efficiency is 0.93. Find the equivalent circuit parameters of this transformer neglecting the no load circuit. [10 Points]
- b- Consider a 2300/230 V single phase transformer whose equivalent series impedance referred to the high voltage side is $Z=0.25 + j 0.4$. Assume that the load on the secondary of the transformer is 400 kVA at 0.85 p.f. lagging with the receiving end voltage maintained at 225 V. Find the active power input at the primary side. [10 Points]

Problem 4

Consider the simple electric power system shown in Figure (2.) Complete the table below:

Bus	$ V_i $	δ_i	P_i	Q_i
Bus 1	1	0	?	?
Bus 2	?	-10°	-0.95	?
Bus 3	1.02	-12°	?	?
Bus 4	0.98	-8°	?	?

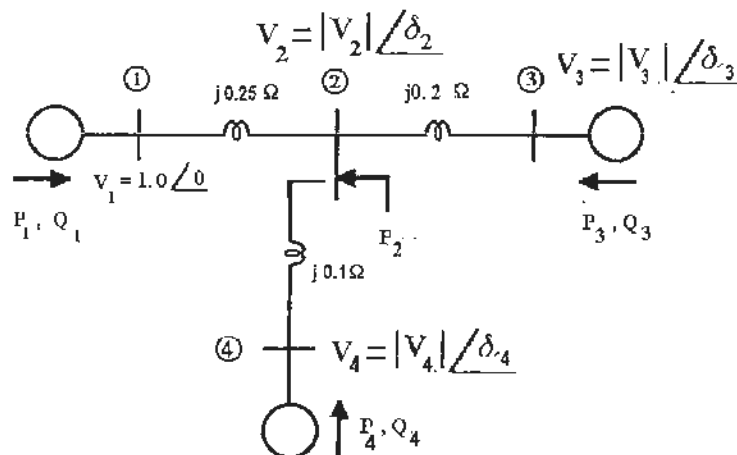

Figure (2) Circuit for Problem 4

PROBLEM 5

- a Discuss the consequences of short circuit faults on electric power systems [5 Points]
- b Protective schemes are routinely used for electric power transformers. Name at least three different types of transformer protective schemes (by function) and explain briefly their principles of operation. [5 Points]

Consider the system shown in the single-line diagram of Figure (3.) All reactances are shown in per unit to the same base. Assume that the voltage at both sources is 1 p.u.

- c Find the fault current due to a bolted- three-phase short circuit in the middle of line B. [5 Points]
- d Find the voltages at buses 4 and 5 under the fault conditions of part c above [5 Points]

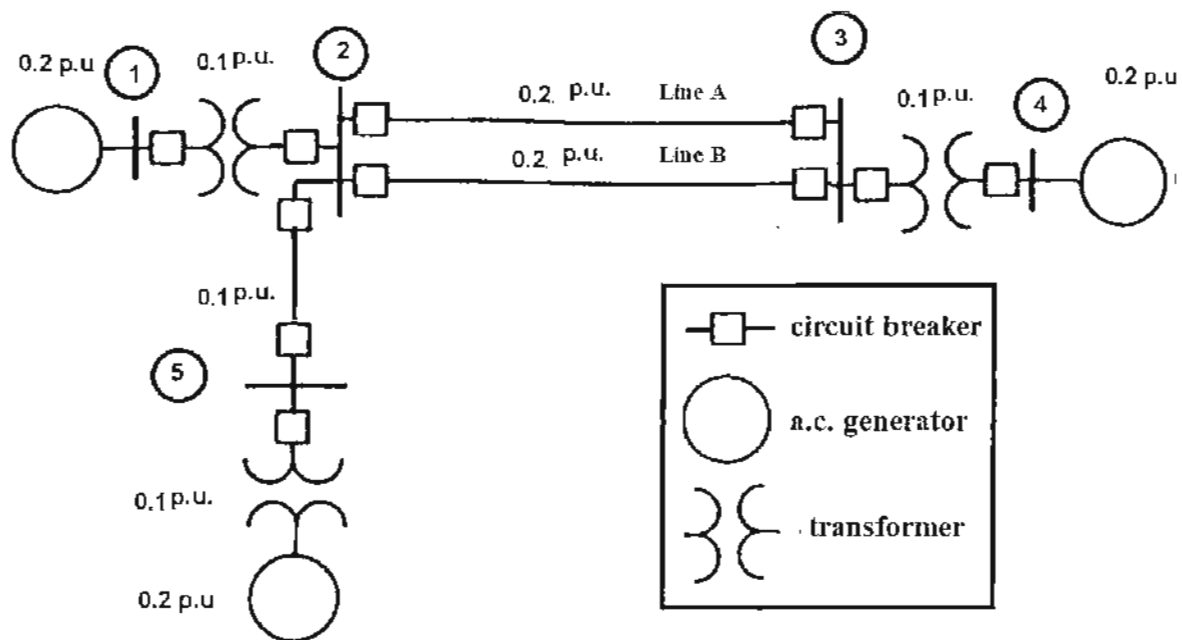

Figure (3) Single-line diagram for Problem 5

PROBLEM 6

Consider the one line diagram of Fig. (4-a,) with corresponding positive, negative and zero sequence networks as given in Fig. (4-b,) Fig. (4-c,) and Fig. (4-d.) A single line to ground fault takes place at bus 2, determine the fault current at bus 3. Assume $E_g = E_{m1} = E_{m2} = 1.0$

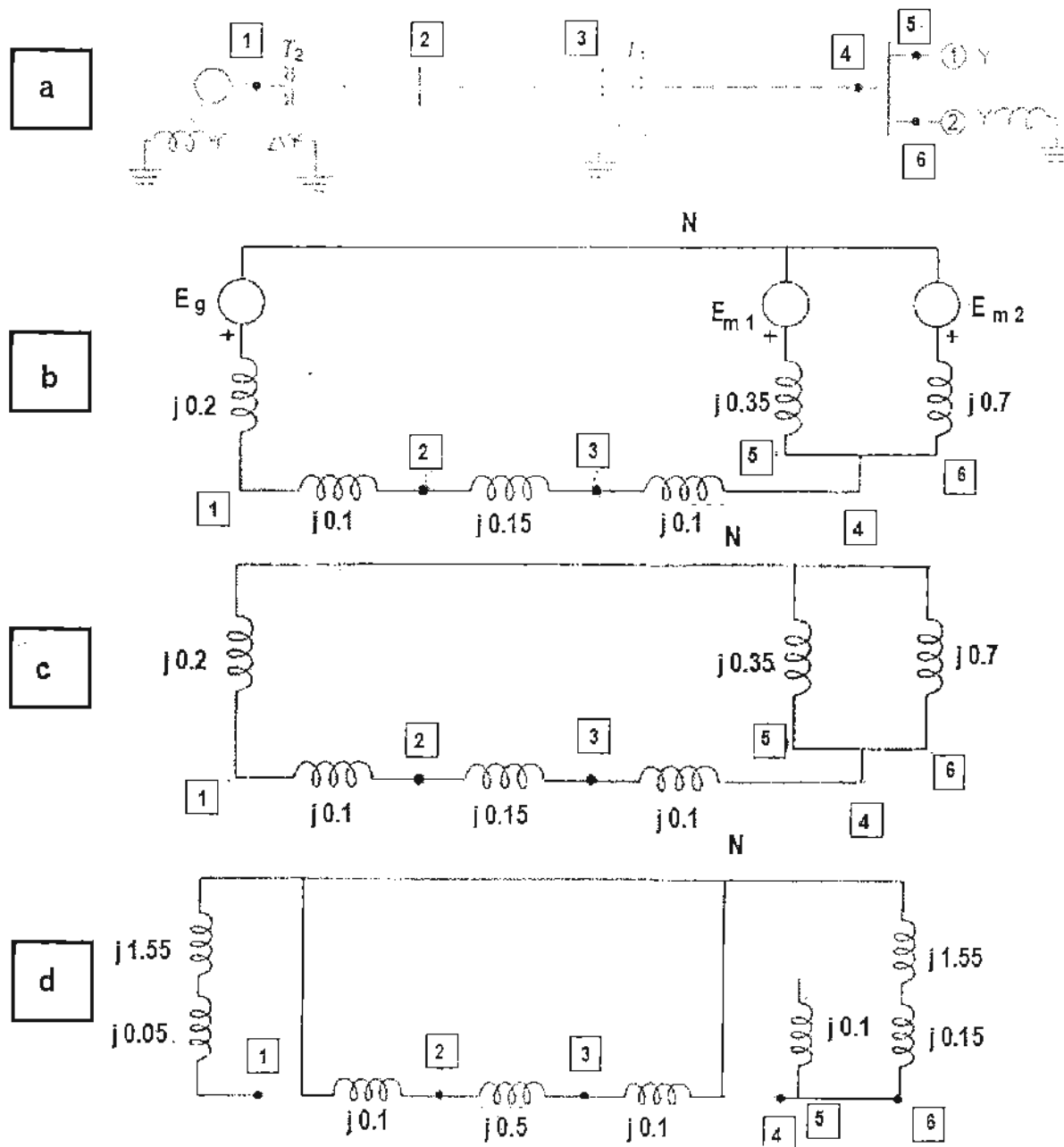

Figure (4) Sequence Networks for Problem 6

Problem 7

Consider the circuit shown in Fig. (5) Assume that $E = 2.4$ p.u., and $V = 1.00$ p.u. The active component of the load on the circuit is 1 p.u., when a three phase short circuit takes place in the middle of transmission line 1.

- a Find the initial power angle δ .

At $\delta_1 = 1.2$ rad, the circuit breakers on both ends of line 1 open to isolate the fault. At $\delta_2 = 1.25$ rad, a fault in the middle of line 2 takes place. At $\delta_3 = 1.9$ rad, the circuit breakers on both ends of line 2 open to isolate the fault. Now the load is served by only one line.

- b Will the system be stable under these conditions

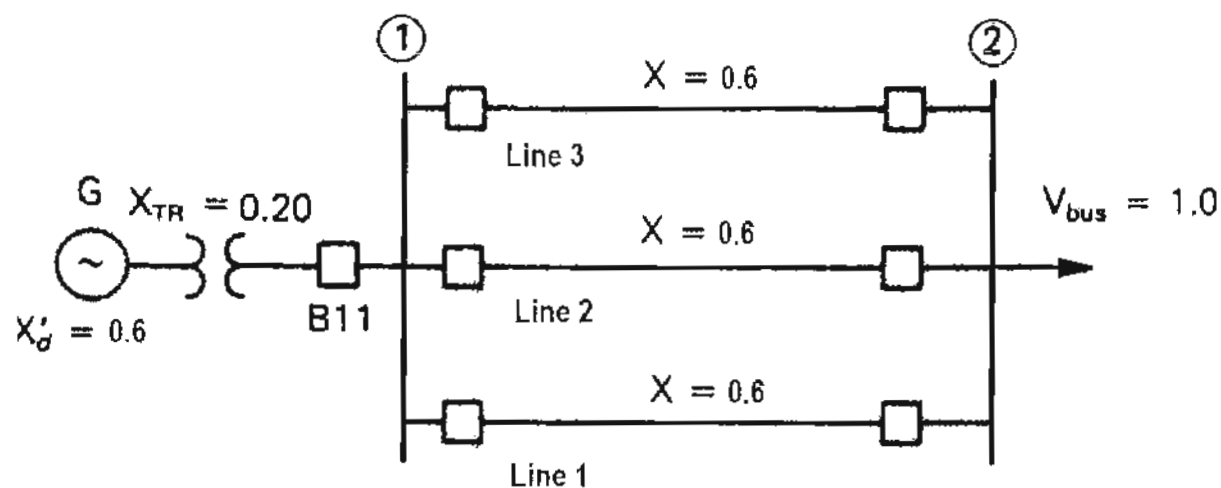

Figure (5) Circuit for Problem 7