

National Exams May 2016

07-Str-B2, **Management of Construction**

3 hours duration

Notes:

1. If doubt exists as to the interpretation of any question, the candidate is urged to submit with the answer paper, a clear statement of any assumptions made;
2. This is a "Closed Book" exam. Candidates may use one of two calculators, the Casio or the Sharp approved models;
3. Any five questions constitute a complete paper. Only the first five questions as they appear in your answer book will be marked.
4. All questions are of equal value.

Marking Scheme

1. 20 marks
2. 20 marks
3. 20 marks
4. 20 marks
5. 20 marks
6. 20 marks

1. Scheduling:

The small project network below shows the activities' names, durations, and relationships. Identify the critical path, and calculate the activities' total floats. What is the effect of delaying activity E one day on the project?

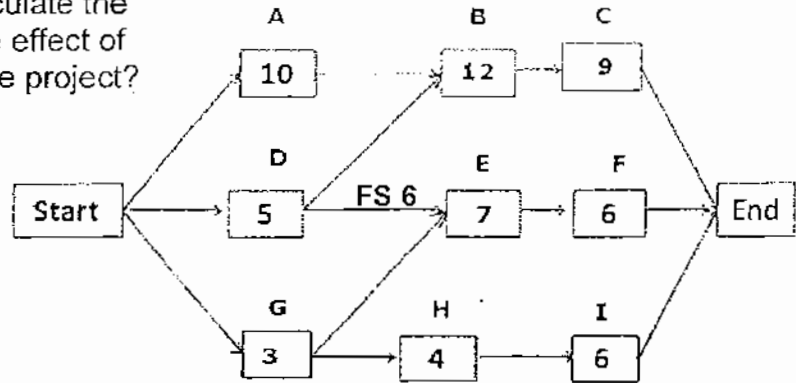

2. Contract Administration:

Briefly explain the process of bid unbalancing, how owners can detect it, and the course of action that can be taken against it. Also, briefly explain the main criteria for selecting the winning bidder for government jobs and highlight its pros and cons.

3. Estimating and Bidding:

In a small project that lasted 6 months, the following list of indirect costs were incurred. Classify each item as a project overhead or a general overhead. Also, classify each item as fixed or variable, then formulate an equation of the total indirect cost in the form of $Y = aX + b$, and explain the parameters of the equation.

Item	Description	Cost
1	Total cost of permits	\$4,500
2	Crane rental	\$17,000
3	Office secretary	\$14,000
4	Cost of project utilities	\$1,200
5	Mobilization cost	\$8,300
6	Batch plant on site	\$12,000
7	Site preparation for work	\$3,800

4. Engineering Economics:

An appraisal of two alternative projects is being carried out. Given the following cash flow, calculate the most economical plan using present value profit. Use discount rate of 10% per year.

	Project A	Project B
Initial Investment	\$60,000	\$70,000
Yearly operating cost	\$2,500	\$1,000
Major Maintenance	\$12,000 (every 3 years)	\$17,000 (every 4 years)
Yearly revenue	\$12,000	\$16,000
Life	9 years	12 years

5. Safety Practices and Regulations:

Briefly discuss each of the following safety measures and if it is suitable for a highway versus building projects, or both:

- | | |
|---------------------------------------|-------------------------|
| 1 Fall protection | 5 Safety net |
| 2 Scaffolding | 6 Respiratory equipment |
| 3 Ladder safety | 7 First aid |
| 4 Personal protective equipment (PPE) | 8 Welding safety |

6. Project Control:

Planned and actual bar charts for a small project are as follows:

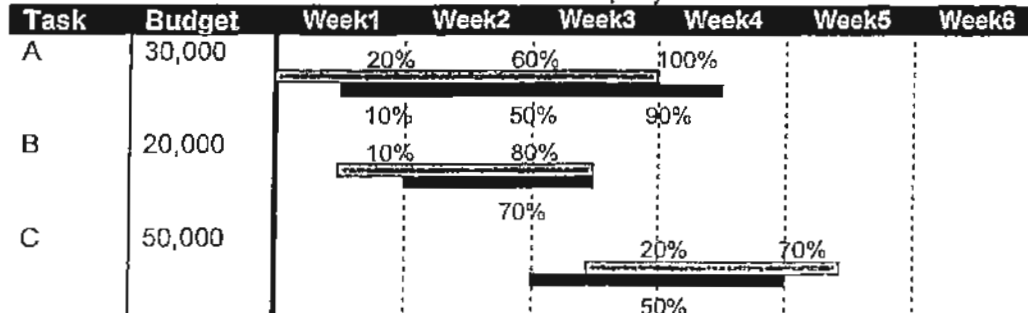

= Plan; and = Actual

- (a) Draw the planned and the actual S-curves. (b) Comment on the actual versus planned progress at end of week 3. (c) By end of week 4, calculate the total expenditures as compared to the planned amount.